

**REPAIR INSTRUCTIONS FOR
JKP AND JKT KEYLESS HIGH PRECISION CHUCKS
JKB AND JKC CNC KEYLESS HIGH PRECISION CHUCKS**

THE JACOBS® HIGH PRECISION SELF-TIGHTENING CHUCK IS IDEAL FOR HIGH PRECISION DRILLING.
MAINTAINING YOUR CHUCK WILL GIVE YOU CONSTANT ACCURACY AND LONGER LIFE.
DISASSEMBLY AND JAW REPLACEMENT:

1. TURN JAWS TO FULLY CLOSED POSITION.
2. CLAMP ON CHUCK BODY IN A VISE WITH SOFT JAWS TO PREVENT SCORING.(FIG.1)
3. REMOVE FIXED RING BY LOOSENING THE RIGHT HAND SET SCREW AND SLIPPING OFF.
4. CLAMP CHUCK IN VISE WITH SOFT JAWS AND LOOSEN FRONT SLEEVE WITH PIPE WRENCH BY TURNING COUNTER-CLOCKWISE. PIPE WRENCH TO HAVE TEFLON INSERTS TO PREVENT SCORING.(FIG.2)
5. REMOVE JAWS FROM LEAD SCREW.
6. REMOVE JAW GUIDE FROM BALL RETAINER BY PULLING FORWARD ON JAW GUIDE. THIS OPERATION IS TO BE PERFORMED ONLY IF PARTS ARE DIRTY.
7. REMOVE LEAD SCREW FROM BODY AND CLEAN ALL PARTS IN SOLVENT AND REPACK BEARING WITH GREASE. APPLY A LIGHT COAT OF OIL OVER ALL PARTS PRIOR TO REASSEMBLY.
8. REASSEMBLE IN REVERSE ORDER. NOTE THAT THE JAWS ARE TO BE REPLACED AS A COMPLETE SET OF 3 EVEN THOUGH ONLY ONE OR TWO OF THE OLD JAWS APPEAR FAULTY OR WORN. WHEN TIGHTENING THE FRONT SLEEVE CLAMP THE CHUCK IN A VISE WITH SOFT JAWS AND TIGHTEN WITH PIPE WRENCH.

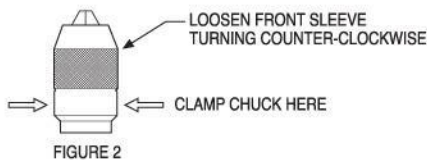
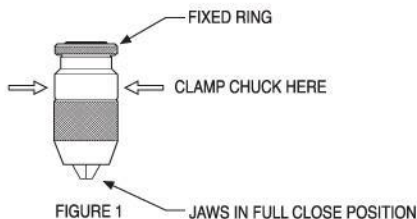
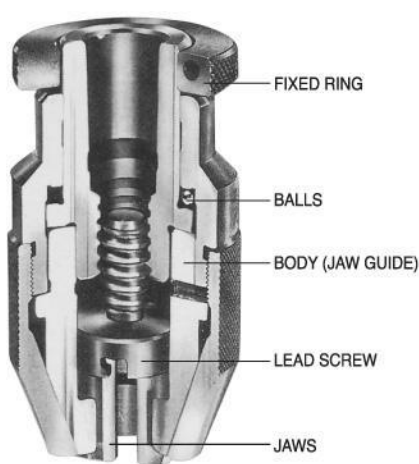

IF THE CHUCK REQUIRES ADDITIONAL SERVICE PLEASE CONTACT JACOBS® CHUCK FOR PROPER SERVICE AND TOLERANCE CHECK.

JACOBS®
CHUCK

Get a better grip.

Post Office Box 592
One Jacobs Road
Clemson, SC 29633-0592 USA
Phone: 864-654-5926